

Agilite™ 560/569



High Energy Nd:YAG
High Energy Nd:YAG
High Energy Nd:YAG
High Energy Nd:YAG

Programmable pulsewidths on a standard platform

Intelligent control architecture for comprehensive system management

Intuitive Graphical User Interface

Single source to support diverse applications

Variable Pulsewidths

Agilite is a high-energy pulsed laser with selectable output pulsewidths. The system comprises an innovative laser design with programmable pulse shaping, a distributed intelligence control system, and an intuitive Graphical User Interface (GUI).

The Agilite Nd:YAG laser is offered with energies to > 600 mJ per pulse, outputs from 50 ns to 50 μ sec, and repetition rates to 20 Hz. Harmonic generators tailored to specific pulsewidths are available.

This unique laser architecture opens new parameter space for diverse applications such as Doppler LIDAR, High brightness Laser Doppler Velocimetry, Ballistic Imaging, and OPCPA pumping.

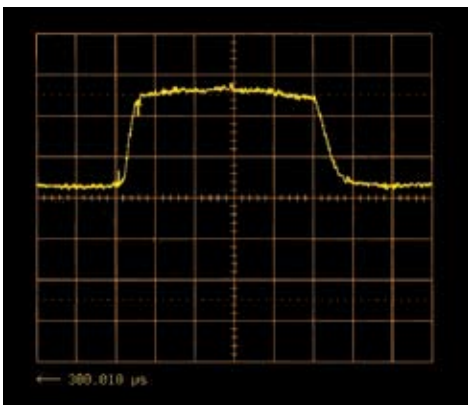

Agilite 560 system output pulse shape

Agilite 560/569 Specifications

Energy (mJ)	Agilite 560				Agilite 569			
Repetition Rate	10 Hz	20Hz			10 Hz	20 Hz		
Wavelength (nm)	1064	532	1064	532	1064	532	1064	532
Modulator 1								
50 ns	90	30	30	8	1100	525	630	275
100 ns	130	35	50	15	1200	550	810	350
200 ns	180	55	80	25	1275	590	900	370
500 ns	250	85	130	40	1360	600	1180	440
1 μ s	310	100	180	60	1450	575	1170	450
2 μ s	360	120	240	80	1530	625	1260	460
5 μ s	440	145	310	100	1530	560	1350	440
10 μ s	500	150	360	85	1600	460	1440	360
Modulator 2								
5 μ s	440	145	310	100	1800	630	1500	495
10 μ s	500	150	360	85	1900	520	1600	405
20 μ s	550	110	420	70	2000	350	1600	270
50 μ s	620	65	490	40	2000	180	1700	140



Agilite 500 Series	
Pulse Duration ¹	50 ns - 10 μ s or 5-50 μ s
SLM Oscillator	Yes
Temporal Profile ²	user selectable
Beam Diameter 560/569	<6 mm / <9mm
Spatial Profile	$M^2 < 1.7$
Pointing Stability	$\pm 50 \mu$ rad
Long Term Stability	<5 % RMS over 8 hr
Linewidth (cm ⁻¹)	<2x transform limit
Beam Divergence	0.5 mrad
Repetition Rate	1-20 Hz available
Shot-to-shot Stability	<2.5 % RMS at 1064 nm
Jitter ³	<2 ns

Notes

- Two configurations (modulator 1 and modulator 2) are available.
- System is configured with one factory set waveform. Additional waveforms are available.
- Measured at 1/2 max leading edge with respect to external modulator trigger.

All specifications at 1064 nm unless otherwise noted. As a part of our continuous improvement program, all specifications are subject to change without notice.

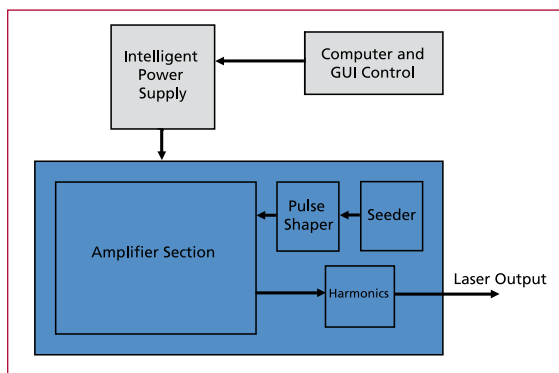

The Agilite 560 system block diagram and GUI screens

Agilite 560/569 System Requirements

Size	Optical Head (L x W x H)	24" x 72" x 13"
	Power Supply (L x W x H)	24" x 28" x 60" (560), 24" x 28" x 70" (569)
Water	Service	1-3 GPM (gallons / minute) at 10 - 40 PSI pressure drop
	Temperature	<22° C / 70° F (higher flow rate for higher temperature)
Electrical Service		220 or 240 VAC, single Φ , 30 A
Room Temperature		18 to 30° C / 65 to 87° F
Umbilical Length		3.81 m (12.5 ft)

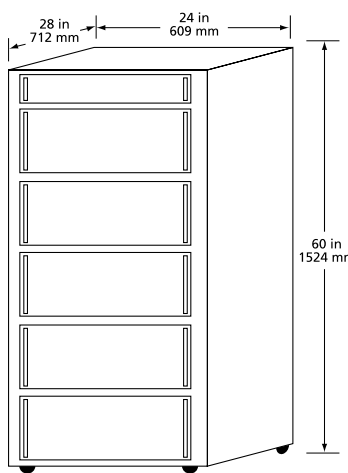
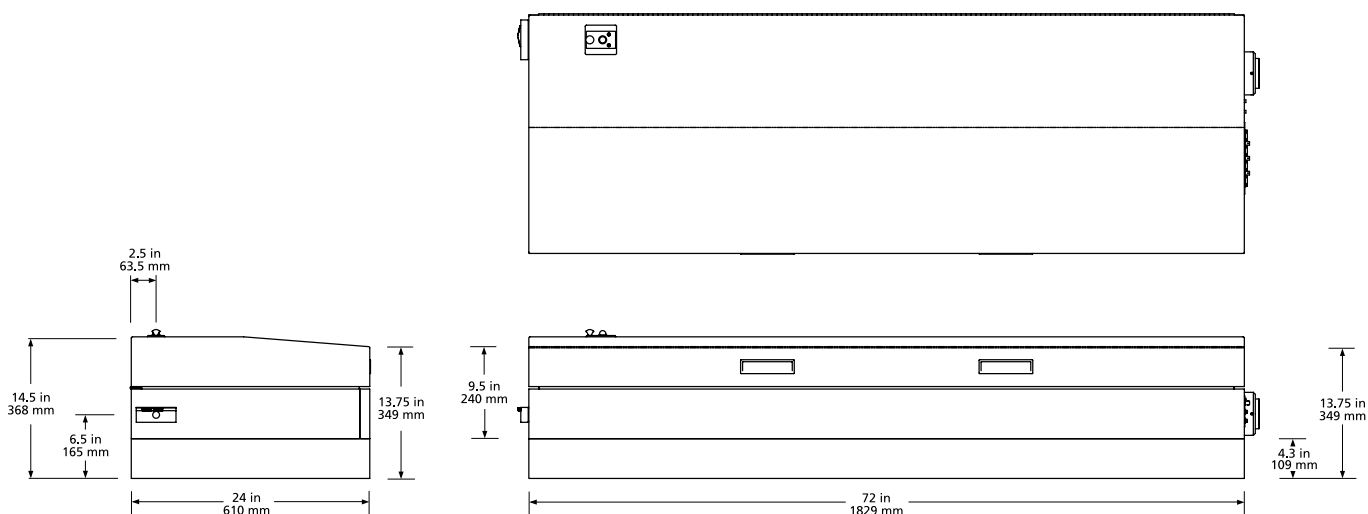

Agilite 560 power supply

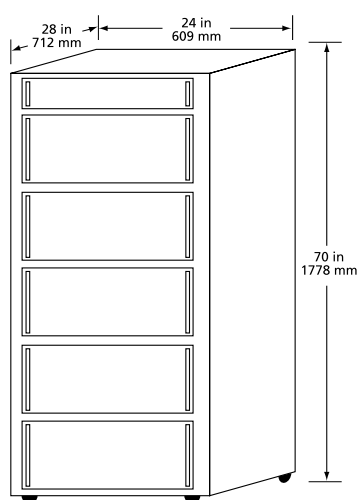

Agilite 569 power supply

Continuum
 3150 Central Expressway, Santa Clara, CA
 Tel (408) 727-3240 Fax (408) 727-8237
 USA Sales (866) 532-1064
 www.continuumlasers.com

992-0089, Rev B 9/10

©2010 Continuum



Continuum[®]
 The High Energy Laser Company™