

# Versatile Tunable Systems Versatile Tunable Systems Versatile Tunable Systems Versatile Tunable Systems

## Sunlite™ EX OPO FX-1

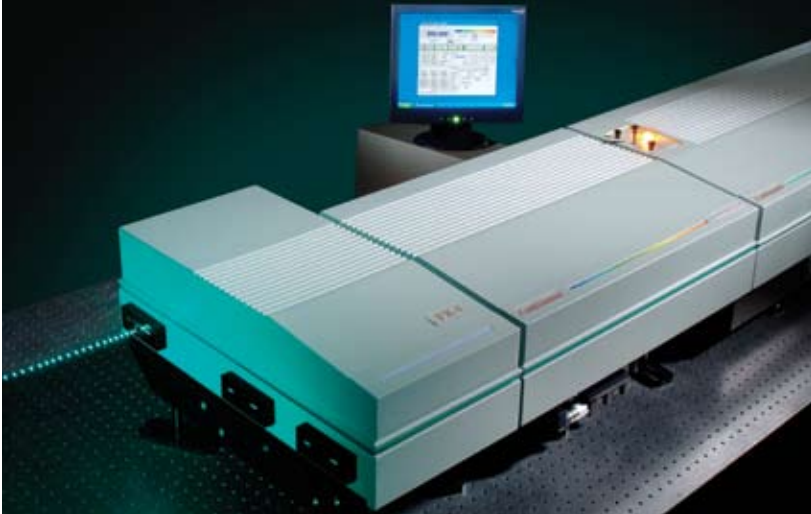

### Frequency Extension Module (FX-1)

The FX-1 frequency extension module extends the performance of the Sunlite EX. This compact package conveniently bolts directly to the Sunlite EX to frequency double the entire

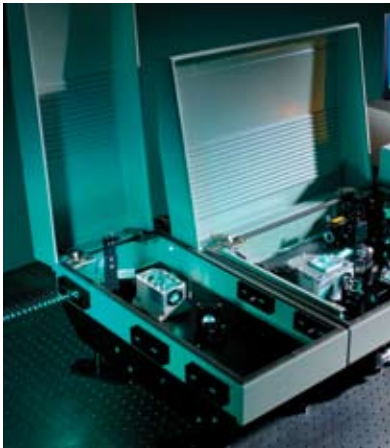

Sunlite OPO output with just a single crystal/optic set. Features such as completely sealed and temperature stabilized crystal ensure not only system longevity, but stable output each and every day. An elegant two crystal configuration immediately compensates for displacement as the system tunes, and a Surepoint Pellin-Broca prism automatically rotates with each scan to ensure that the doubled

output beam always remains *fixed in one location*.

Also designed into the FX-1 package is easy access to the Sunlite signal and idler wavelengths. Now you have complete access to a system that operates from 222.5nm all the way to 1750nm.

Simply select your wavelength of interest, scan range, and step time and our Windows® software platform will guarantee optimal fundamental and doubled output.

### Features and Benefits

**Optimized OPO pump laser, Powerlite 10 or 20 Hz**

**Broad Tunability - 225.5nm - 450nm (no degeneracy)**

**Excellent linewidth , <0.3 cm<sup>-1</sup>**

**Convenient - one optic set covers the entire FX-1 tuning range**

**Direct access to the fundamental, 445nm-1750nm - no need to remove the FX-1 module**

**Rugged - bolts directly to the Sunlite**

**Hermetically sealed & temperature stabilized crystal housing - stable and long lifetime operation**

**Ease of use – computer control of entire system – an intuitive Windows® platform with RS-232 interface**

# FX-1 Specifications

Description	PL 8000	PL 9010	PL 9020
Repetition Rate	10	10	20
Tuning Range (nm)	222.5nm - 450nm		
Signal Range (nm)	222.5nm - 355nm		
Idler Range (mJ)	355nm - 450nm		
Pulwidth <sup>1</sup> (nsec)	3-6		
Linewidth (cm <sup>-1</sup> )	<0.3	<0.3	<0.3
Divergence <sup>2</sup> (mrad)	<1.5	<1.5	<2.0
Signal Energy (at peak, mJ)	6	10	5
Idler Energy (at peak, mJ)	3	6	2
Pointing Stability <sup>3</sup> (± μrad)	50	50	75
Energy Stability <sup>4</sup> (±%) at 275nm	15	15	20
Polarization (%)	Horizontal >99		

## Notes

1. Full width half max
2. Full angle for 86% (1/e<sup>2</sup>) of energy
3. 99.9% of shots with ΔT<sub>room</sub> < ±3 °C
4. Shot-to-shot for 99.9% of pulses

All specifications at 275nm unless otherwise noted. As a part of our continuous improvement program, all specifications are subject to change without notice.

## Typical Doubled Output Sunlite EX OPO FX-1 pumped by a Powerlite 9010

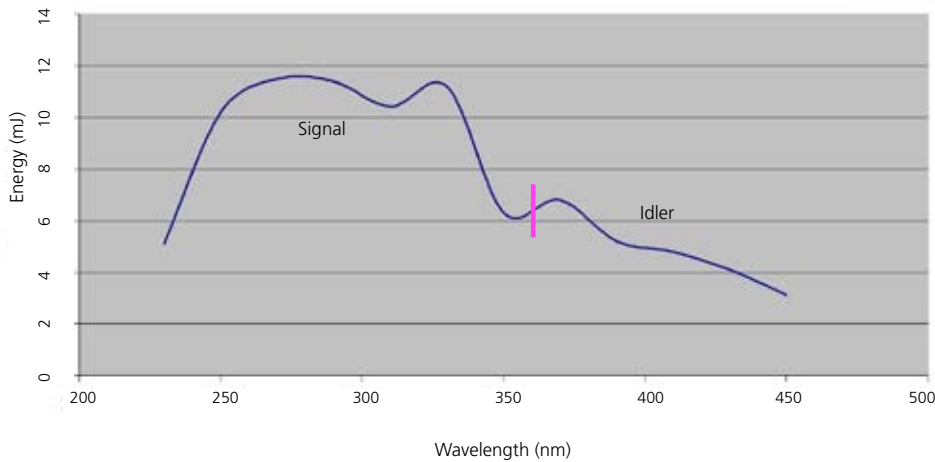

## FX-1 Physical Layout

All dimensions are in mm (inches)

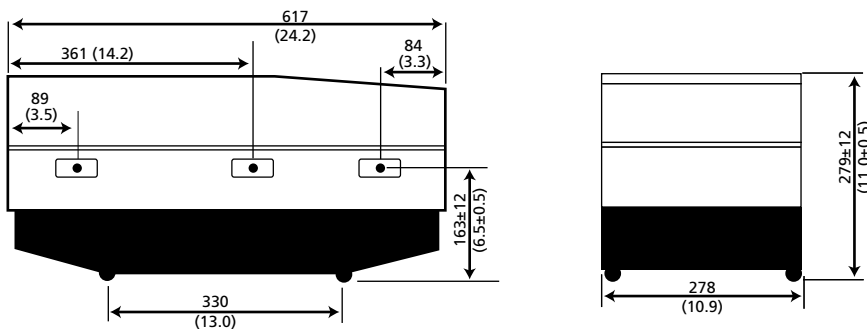

Continuum  
3150 Central Expressway, Santa Clara, CA  
Tel (408) 727-3240 Fax (408) 727-8237  
USA Sales (866) 532-1064  
www.continuumlasers.com

992-0034, Rev. A 9/2011

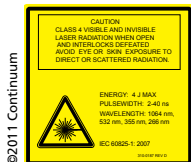

©2011 Continuum

**Continuum**<sup>®</sup>  
The High Energy Laser Company™