

## Minilite™



### Minilite

The Minilite is Continuum's entry level Q-switched Nd:YAG laser system. It is designed for new and existing users of pulsed lasers allowing easy operation, simple external control and compact size. It provides high levels of performance while maintaining a very reasonable price point.



The Minilite platforms offer users accessible harmonic generators, integrated energy attenuator and simple operation. Both the Minilite I and II lasers, use a single YAG rod/flashlamp pump chamber, invar resonator, and a stable resonator design which offers maximum energy extraction and excellent beam quality.

Minilite series lasers are used for remote sensing, sample testing, mass spectroscopy, LIF and laser flash photolysis.

High Energy Nd:YAG  
High Energy Nd:YAG  
High Energy Nd:YAG  
High Energy Nd:YAG

*Can be operated locally or remotely via TTL interface*

*No need for an external water hook-up, the system is completely self-contained*

*Easy flashlamp replacement without alignment of the laser oscillator*

*Invar resonator structure ensures long-term thermal and mechanical stability*

*Variable attenuator included*

# Minilite Specifications

Description	ML I	ML II
Repetition Rate (Hz)	1-15	1-15
Energy (mJ)		
1064 nm	28	50
532 nm	12	25
355 nm	4	8
266 nm	2	4
Pulsewidth <sup>1</sup> (nsec)		
1064 nm	5-7	5-7
532 nm	3-5	3-5
355 nm	3-5	3-5
266 nm	3-5	3-5
Linewidth (cm <sup>-1</sup> )	1	1
Divergence <sup>2</sup> (mrad)	<3	<3
Rod Diameter (mm)	3	3
Jitter <sup>3</sup> (±ns)	0.5	0.5
Energy Stability <sup>4</sup> (±%)		
1064 nm	2.0;0.6	2.0;0.6
532 nm	3.0;1.0	3.0;1.0
355 nm	4.0;1.3	4.0;1.3
266 nm	8.0;2.6	8.0;2.6
Polarization		
1064 nm	Horizontal	Horizontal
532 nm	Vertical	Vertical
355 nm	Horizontal	Horizontal
266 nm	Horizontal	Horizontal

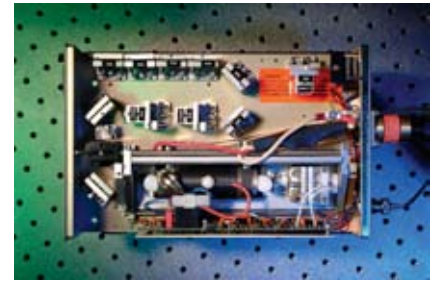

## Notes

1. Full width half max
2. Full angle for 86% (1/e<sup>2</sup>) of energy
3. With respect to external trigger
4. The first value represents shot-to-shot for 99.9% of pulses, the second value represents RMS

All specifications at 1064 nm unless otherwise noted. As a part of our continuous improvement program, all specifications are subject to change without notice.

# Minilite System Requirements

Size	Optical Head (LxWxH)	267 x 172 x 63.5 mm (10.5 x 6.75 x 2.5 in)
	Power Supply (LxWxH)	381 x 197 x 365 mm (15 x 7.75 x 14 in)
Weight	Optical Head	3.6 kg (8 lbs)
	Power Supply	14.5 kg (32 lbs)
Water		closed loop water to air heat exchanger: external cooling water not required (10 oz. deionized water per PS)
Electrical Service		110 V (4 A)
		220 V (2A), 50/60 Hz
Room Temperature		18 to 30° C / 65 to 87° F
Umbilical Length		3.18 m (10.4 ft)

## Minilite Physical Layout

All dimensions are in mm (inches)

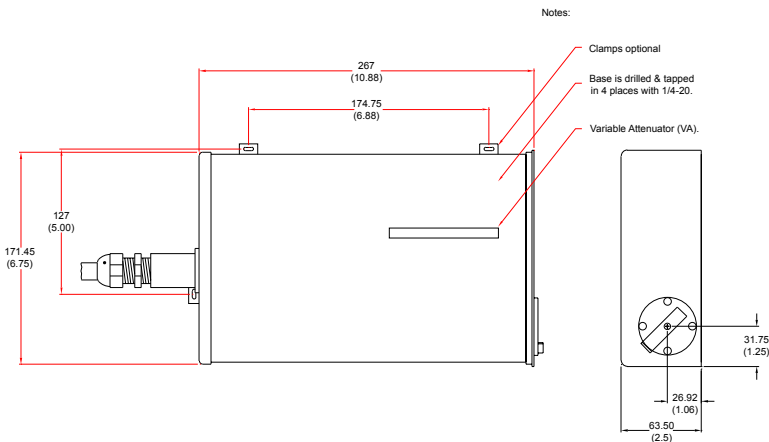

## Minilite Power Supply

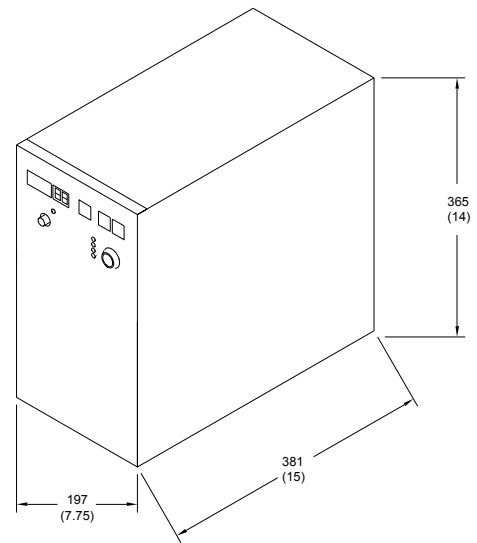

Continuum  
 3150 Central Expressway, Santa Clara, CA  
 Tel (408) 727-3240 Fax (408) 727-8237  
 USA Sales (866) 532-1064  
 www.continuumlasers.com

992-0024, Rev. D 03/10



© 2010 Continuum

**Continuum**<sup>®</sup>  
 The High Energy Laser Company™